

UF | GETS THE JOB DONE.

The powerful utensil washer



One machine for perfect cleanliness and hygiene. Perfectly coordinated accessories. Specially-developed chemicals. Advice. Training services. Service. All that and more from Winterhalter.



ERGONOMIC OPERATION

Touch screen and quick-start button. Fold-back door. Rack dolly and swing rack. These and many other features make operation of the UF easy and particularly ergonomic.

QUALITY AND RELIABILITY

Washing utensils under extreme conditions. The UF Series is specially designed for this: the high-quality materials and solid finish make the machine robust, reliable and extremely durable.

PERFECT WASH RESULTS

Whether it's proteins, starch or grease: the UF deals with extremely heavy and stubborn soiling. With a high-performance washing system and a soaking programme, it is perfectly designed for the professional washing of utensils.



FULL POWER.

This is the real test for a warewasher. Extremely stubborn soiling. On a variety of utensils. When washing becomes a challenge, the UF Series from Winterhalter is in its element. Robust design. With immense power. And innovative features: for excellent wash results and maximum hygiene. Are you a baker, butcher or caterer who washes dishes in extreme conditions? The UF is the machine for you.

CUSTOMISED SOLUTION

Perfectly adapted to your dishes: the UF is available in three different sizes. The compact UF-M is ideal for smaller and medium-sized utensils. The UF-L has additional entry height that allows even large baking trays to be washed. And the UF-XL has sufficient capacity for large and bulky utensils.

HYGIENE SAFETY

Wherever food is in a working environment, hygiene standards apply. The UF ensures that you can comply with these easily: with a well conceived machine interior. It is based on a machine construction that makes cleaning very easy.



A detailed overview of the UF Series is available on our website at:

>> www.winterhalter.com/uf





HIGH-PERFORMANCE WASHING SYSTEM

Every UF comes with a stainless steel high-performance washing system as standard: the special geometry of the wash arm and a water pressure of up to 1 bar ensures optimal cleaning performance throughout the entire interior of the machine. The »VarioPower« variable water pressure system ensures that the washing pressure can be adjusted to suit how dirty the wash items actually are. The result: perfectly washed utensils and maximum hygiene.

FOLD-BACK DOOR

With the UF Series utensil washers, it's not just washing that runs smoothly. Cleaning the interior of the machine is also a breeze: the optional fold-back door can be unlocked and simply folded down. This means there is nothing in the way, and the interior of the machine is easily accessible.

RACK DOLLY

Ergonomic. Practical. Uncomplicated. With a rack dolly, which is available as an accessory, bulky and heavy wash items can be collected quickly and transported to the machine with ease. Once there, the rack is simply pushed directly from the dolly into the machine. And after washing, everything can be sorted and put away just as quickly. For optimal workflow in the kitchen.

HEAT RECOVERY

Intelligent use of energy: as an option, the UF can be fitted with integrated »Energy« circulating air heat recovery. This uses the energy from the hot steam to pre-heat the cold inlet water. This significantly reduces energy consumption, lowers operating costs and ensures that hardly any steam escapes when the machine is opened.

COLD WATER PRE-WASH

Anyone who works with proteins and starch will know: it's important to pre-wash with cold water to avoid baking the dirt onto the wash items. All UF Series utensil washers can be equipped with cold water pre-washing as an option. Clean, cold water releases the dirt before the actual wash cycle begins. This guarantees a hygienically clean wash result and reduces the work involved in manual pre-washing.

WARM WATER INITIAL FILL

The machine is ready to start in just a few minutes: as an option, the UF can be configured so that the tank is filled directly with warm water. The warewasher is therefore ready for operation more quickly and consumes less energy. Of course, the same applies when changing the tank water in the course of a washing day.





»As a cooking school, we have specific requirements for a warewasher. It has to be quick so we lose as little time as possible during courses. It must be suitable for bulky baking sheets and large cooking pots. And it also has to reliably remove stubborn leftovers – as our pupils burn things from time to time. The UF does this brilliantly. And to top it all off, it's really easy to use!«

Małgorzata Michalska, OWNER OF THE ASHANTI INTERNATIONAL COOKING SCHOOL | ŁÓDŹ, POLAND

Cleanliness and hygiene. Every single one of our products plays its part. Together they create the perfect wash result. Welcome to the complete Winterhalter system!

UTENSIL RACKS AND RACK ACCESSORIES

Pots and bowls. Kitchen utensils. Equipment. The utensil racks from Winterhalter have been specially developed for bulky wash items. They are extremely strong and, thanks to their open stainless steel design, allow maximum water permeability. Special sliders make it easy to insert and remove the racks – which is particularly useful for heavy wash items. Whatever you are washing: there is a customised rack for your UF.

But Winterhalter not only has the right rack system for every application. The special accessories turn every rack into a completely individual solution. For bakeries, there are special inserts for cake rings and piping bags. For butcher's shops, there are inserts for chopping boards and knife blocks. And with an additional intermediate shelf, you can easily double the capacity.

Washing racks and rack accessories protect your wash items and deliver first-class wash results and fast drying. We will be happy to advise you on which racks best suit your requirements. Culminating in the best solution for you.



WATER TREATMENT

Trays, utensils, containers. Many of them made from delicate materials. Nearly all of them with heavy soiling. Washing utensils really is a tough job. There's a simple rule here: as effective as necessary, as gentle as possible.

Warewashers from Winterhalter achieve this balancing act in combination with the right water treatment devices: they reduce the mineral content in hard water and deliver consistently soft water. This offers several simultaneous advantages: smaller amounts of detergent and rinse aid are needed to do their job effectively. Better wash results ensure maximum hygiene. And the machine is continuously protected from harmful limescale deposits.





CHEMICALS

They are usually overshadowed by the machine. Often underestimated. But they have a crucial influence on the wash result: the chemicals. For this reason they are an extremely important component within the overall Winterhalter system.

At our headquarters in Meckenbeuren we have established a research department with an in-house laboratory. Here we develop and test formulas for a premium range of detergents and hygiene products. These are precisely tailored to the different wash items and types of contaminants; they are economical and can be ideally combined with other products in the range. They work together perfectly and deliver a brilliant overall wash result.

SPECIALLY DESIGNED FOR UTENSIL WASHING

Proteins, starch, grease. Burnt on and encrusted. Washing utensils represents a particular challenge for a warewasher. The UF Series from Winterhalter is ideally equipped for this. The standard soaking programme ensures, that dried and baked-on dirt is softened and released before the actual wash cycle begins.

For the very toughest jobs, the UF is available with the special »TurboZyme« soaking process. This involves soaking the wash items with the special »Crust Cracker« chemical before the actual wash cycle begins, in order to release stubborn dirt effectively. This ensures an optimal wash result, even in the toughest of cases, and simultaneously saves time and effort: manual pre-washing becomes easier and can even be left out altogether.



ADVICE AND SERVICE

Winterhalter is the specialist in commercial warewashing systems. Our knowledge encompasses the widest range of kitchens in the world. We know which aspects are important when it comes to washing, and what has to be taken into consideration. And: we enjoy passing this knowledge and experience on to our customers.

The aim: a perfect washing process. Behind every UF Series warewasher are the high Winterhalter standards for a complete solution for your washing process. How can the warewashing system be adapted precisely to your available space and work processes? Which optional accessories make sense for your applications? What options are there for optimising your workflow? We help you answer every single question. So that you can make the right choices for your investment.

Your partner, Winterhalter. Our team of advisers and planners analyse your individual on-site conditions: the layout, the room arrangement, the processes. We plan your requirements and calculate the necessary equipment. We help you organise your washing operation, optimise the washing logistics and provide instruction and training sessions for your employees. And, of course, we take care of all the service and maintenance work – so that your machine can operate for as long as possible and you do not experience any downtime. In short: when it comes to washing, we're always there for you. From the start. And we help you to make your washing process as professional and efficient as possible.

What can we do for you? Let's talk about it: Tel. +49 7542 402-5408 or www.winterhalter.com/contact



Karl Winterhalter



Jürgen Winterhalter



Ralph Winterhalter

»We are family people!«

Down-to-earth. Forward-looking. With a focus on family. The culture and values of our family have shaped the Winterhalter company for three generations. Close to staff, customers and partners. Long-term thinking with a view to the generations to come. Taking personal responsibility – all typically Winterhalter. We are proud of our family company. And we are pleased to grow a little more every day.

THE FIRST WINTERHALTER



It all began in 1947: Karl Winterhalter established his own company in Friedrichshafen. He started by salvaging scrap metal from the war, which he used to manufacture household goods. Cooking pots and ovens, for example. A short time later he specialised, and in 1957 launched the GS 60 model: the first commercial warewasher from Winterhalter. That was the starting signal. Since then the company has always pursued a single goal: perfect wash results as part of an efficient washing process. With this holistic approach, Winterhalter has developed from a machine supplier to the full system provider of warewashing solutions it is today.

»Products, advice, service – three factors that intertwine seamlessly at Winterhalter. And that makes our customers feel safe in the knowledge that they have the right partner for any issue relating to the washing process.«

FROM WAREWASHER TO WAREWASHING SOLUTION

In days gone by, all we needed to do was deliver the new warewasher to our customer's kitchen on a hand truck. Now it's about the development of a new, individual warewashing solution, which is perfectly coordinated with the on-site situation and the special requirements and preferences of the customer. A solution of this type is based on clear analysis and planning. To achieve this, we visualise the room layout using state-of-the-art CAD software in 2D and 3D. For a bespoke and efficient washing process.



OVER **2.000**
EMPLOYEES WORLDWIDE

High quality standards. Diligence. Curiosity and ambition. These are the typical attributes of a Winterhalter employee. And with them, we have grown from a small Swabian family company into a global player: with over 40 branches worldwide and distribution partners in over 70 countries. We are proud of what we have achieved. And we are proud of each and every employee who has done their bit. So we would just like to take this opportunity to officially say »Thank you!«



OUR ACADEMY OF WASHING SCIENCE

Almost 1,000 participants per year and 250 training days worldwide: as part of our training programmes we pass on our knowledge and experience in the discipline of »warewashing«. We provide training to our own personnel as well as to our retail and service partners. Our objective: every Winterhalter customer should receive informed advice and professional support in the specific situation. Whether it's an initial informative discussion, installing a warewasher, or service and maintenance appointments.

IN-HOUSE LABORATORY FOR IMPROVED CHEMICALS

As a specialist in warewashing, do we want to rely on the products of other manufacturers? The answer to this question was an immediate and resounding »No!«. This was the moment when our in-house research laboratory was born: we have been developing our own formulas for original Winterhalter chemicals for many years now: from detergents and rinse aids to hygiene products.

Good to know

As a specialist in warewashing, at Winterhalter we set high standards for ourselves: we don't just want to meet our customers' current requirements. We want to support them proactively and gain their trust for the long term. Service plays an important role here: our comprehensive network guarantees fast and professional support on site. Worldwide.

We and our service partners are there when you need us. On that you can always rely with Winterhalter.



What opportunities does new technology offer? How is our society and the world of work changing? Which trends and developments will shape commercial warewashing in the future? We find all of these questions extremely exciting. And that's why we are already working on developments that will affect us and our customers tomorrow, and the day after that. You can take a look at the solutions that we have developed in our NEXT LEVEL SOLUTIONS. Current examples include CONNECTED WASH and PAY PER WASH.

>> www.connected-wash.com >> www.pay-per-wash.com

»See you again soon!«

Customers often own a Winterhalter warewasher for 15 or 20 years. So our customers only have to worry about disposing of their old equipment once every few decades. What's more, we take care of this ourselves. We design our machines as modular systems, so they are easy to dismantle if ever the need arises. We reduce the range of materials, use standardised construction materials and label plastic parts for easy recycling. Winterhalter warewashers have a particularly high recycling ratio thanks to these and many other measures.



MADE IN GERMANY AND SWITZERLAND

As ever, it is not simply an indication of origin, but a seal of quality: products made in Germany and Switzerland are recognised worldwide for their premium quality and total reliability. For engineering skill, ingenuity and precision. Winterhalter is the perfect testament to this: in Meckenbeuren, Edingen and Rüthi, we develop and produce solutions for first-class cleanliness and hygiene. This is our promise for every single warewasher that leaves our factory.

GENERAL TECHNICAL DATA: UF SERIES

UF-M

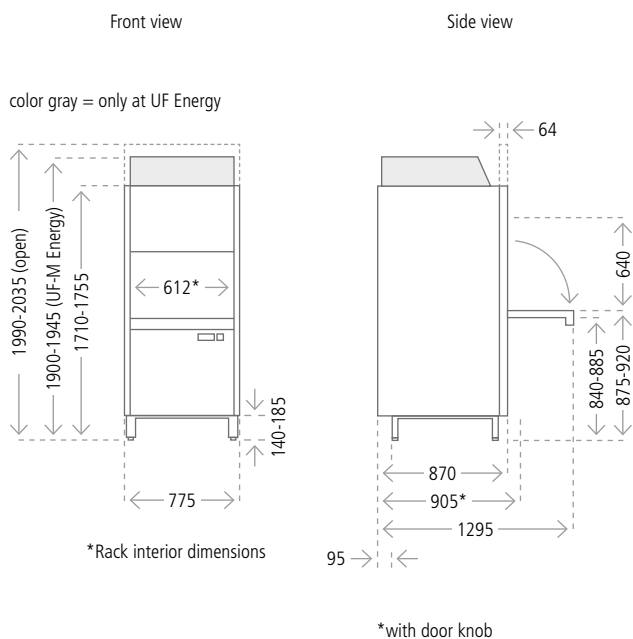

UF-L

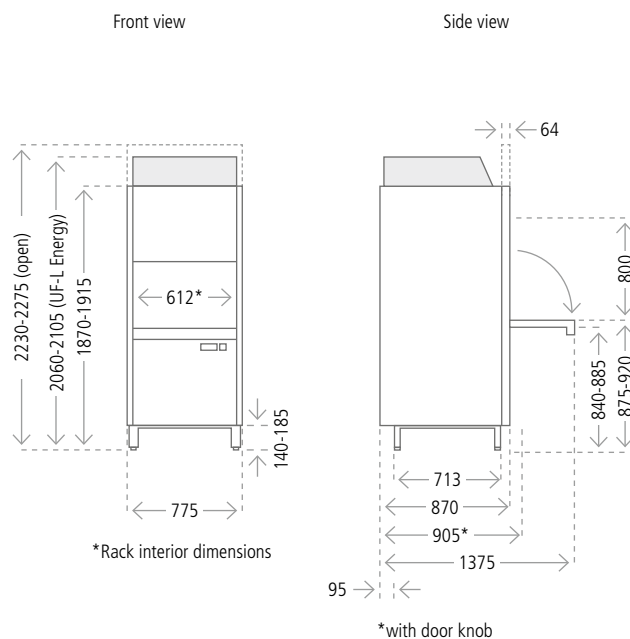

General data		UF-M	UF-L	UF-XL
Tank capacity	l	69	69	138
Rack interior dimensions	mm	612 x 672	612 x 672	1305 x 672
Clear entry height	mm	640	800	800
Wash pump	kW	2.5	2.5	2 x 2.5
Noise emission	dB(A)		< 70	
Splash guard			IPX5	
Weight net/gross	kg	190 / 220	200 / 230	305 / 355
Weight with Energy version net/gross	kg	225 / 255	235 / 265	350 / 400
Max. inlet water temperature	°C		60 (Energy: 20)	
Required water flow pressure	bar / kPa		1 – 6 / 100 – 600	
Required water flow pressure with Energy *1	bar / kPa		1.5 – 6 / 150 – 600	

Specific data				
Theoretical capacity standard *2	Racks/h		12 / 24 / 40	
Theoretical capacity short programme *2	Racks/h		23 / 42 / 64	
Theoretical capacity HighTemp *3	Racks/h		10 / 15 / 20	
Rinse water consumption per wash cycle *4	l	4.7	4.7	7.0
Rinse water consumption per wash cycle HighTemp *4	l	5.5	5.5	9.0
Tank temperature	°C		63	
Tank temperature HighTemp	°C		66	
Rinse temperature	°C		85	

UF-XL

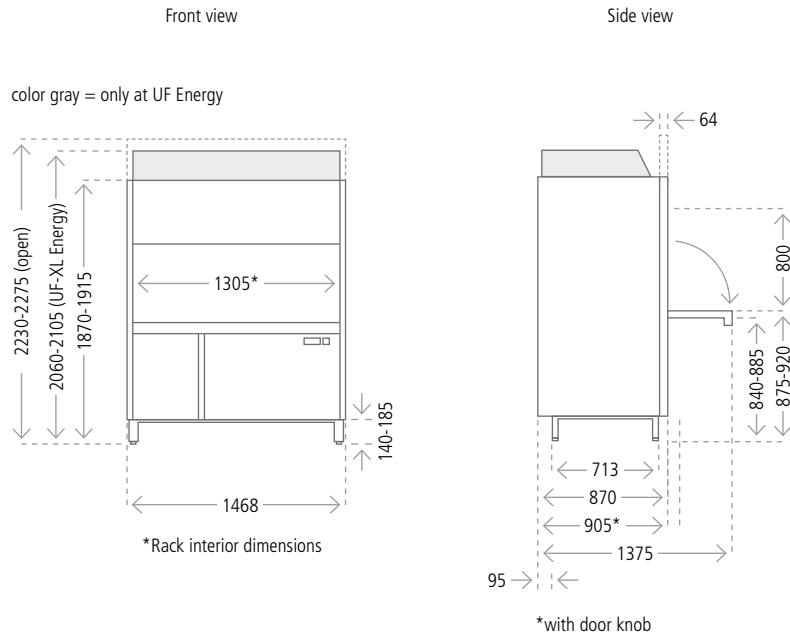

ELECTRICAL DATA

Voltage	Fuse protection	Total connected load Standard Tank heating 5kW* ⁵ Boiler heating 10.2kW* ⁵		Total connected load Performance Tank heating 10kW* ⁵ Boiler heating 16.4kW* ⁵		Countries
		UF-M/L	UF-XL	UF-M/L	UF-XL	
380V, 3N~, 50 Hz/60 Hz	16A	8.7 kW	8.4 kW	–	–	Worldwide
	16A	9.4 kW	8.8 kW	–	–	
	20A	10.0 kW	10.0 kW	–	–	
	25A	16.3 kW	16.2 kW	16.4 kW	16.4 kW	
	32A	17.5 kW	17.4 kW	18.8 kW	18.8 kW	
400V, 3N~, 50 Hz/60 Hz	40A	–	–	25.1 kW	26.2 kW	
	16A	10.0 kW	9.5 kW	–	–	
	20A	10.8 kW	10.8 kW	–	–	
	25A	17.4 kW	17.1 kW	17.7 kW	17.7 kW	
415V, 3N~ 50 Hz /60 Hz	32A	18.7 kW	18.4 kW	20.3 kW	20.3 kW	
	40A	–	21.1 kW	25.5 kW	26.8 kW	
	25A	9.4 kW	8.7 kW	–	–	
	32A	10.2 kW	9.9 kW	–	–	
230V, 3~, 50 Hz/60 Hz	40A	–	–	15.2 kW	15.1 kW	Belgium
	50A	–	–	17.7 kW	17.6 kW	
	25A	7.6 kW	9.1 kW	–	–	
200V, 3~ 50 Hz/60 Hz	32A	9.0 kW	–	10.3 kW	10.3 kW	Japan
	40A	–	–	12.2 kW	12.9 kW	
	50A	–	–	15.9 kW	16.8 kW	
	–	–	–	–	–	

*1 Inlet water temperature < 20 °C.

*2 Depending on local conditions (inlet water temperature / electrical supply), the values stated here may be reduced.

*3 Minimum 25A fuse protection, tank and boiler heating performance.

*4 Non-binding information. The actual rinse water consumption may vary depending on the on-site conditions.

*5 The actual power varies depending on the mains voltage.



»In this brochure, we have presented our UF Series: its product features, application options and what sets it apart. However we were not able to provide you with the strongest argument of all here: the positive experiences of our satisfied customers. Just ask next time you see a UF anywhere. There is no better aid to making your decision.«

Jürgen and Ralph Winterhalter